

A structural model and an approximate method for calculating the permeability of porous materials are proposed.

We will examine the laminar flow of a viscous fluid in a porous medium caused by a pressure gradient. In accordance with Darcy's law, let the volumetric flow rate of the fluid in a layer of the porous material (Fig. 1a) be proportional to the permeability  $k$ , the pressure drop  $\Delta p$  over the length  $L$ , and the section  $S = \ell h$  and inversely proportional to the dynamic viscosity of the fluid  $\mu$ :

$$q = k \frac{S}{\mu} \frac{\Delta p}{L}. \quad (1)$$

We will examine a mixture of two porous materials with known permeabilities  $k_1$  and  $k_2$  and volume concentrations  $m_1$  and  $m_2$ , where  $m_1 + m_2 = 1$ . We will prove that it is possible to calculate the effective permeability  $k = f(k_1, k_2, m_2)$  for different structures of mixtures. For this purpose, we first investigate the simplest combinations of structures and then proceed to more complex combinations.

We will begin the analysis with adjacent "butts" of porous materials (Fig. 1b) for which, on the basis of Eq. (1), the following relations are valid

$$q = \frac{k_1}{\mu} \frac{\ell h}{L_1} \Delta p_1 = \frac{k_2}{\mu} \frac{\ell h}{L_2} \Delta p_2. \quad (2)$$

From Eq. (2), it is not difficult to find the total pressure drop  $\Delta p$  over the length  $L = L_1 + L_2$ :

$$\Delta p = \Delta p_1 + \Delta p_2 = \frac{q\mu}{\ell h} \left( \frac{L_1}{k_1} + \frac{L_2}{k_2} \right). \quad (3)$$

We substitute for the system of bodies (Fig. 1b) a quasiuniform body with a transverse section  $\ell h$ , length  $L$ , pressure drop  $\Delta p = \Delta p_1 + \Delta p_2$ , and effective permeability  $k$ . Equation (1) is valid for such a body, and in comparing Eqs. (1) and (3) we find

$$\frac{1}{k} = \frac{m_1}{k_1} + \frac{m_2}{k_2}, \quad m_i = \frac{L_i}{L} = \frac{V_i}{V} \quad (i = 1, 2). \quad (4)$$

For a system in which the layers are parallel to each other and the flow (Fig. 1c), assuming that the total flow is equal to the sum of the flows  $q = q_1 + q_2$ , we obtain the following expression for the effective permeability

$$k = k_1 m_1 + k_2 m_2, \quad m_i = \frac{h_i}{h} = \frac{V_i}{V} \quad (i = 1, 2). \quad (5)$$

It is not difficult to obtain the following relation for  $k$  for the system shown in Fig. 1d:

$$k = k_1 m_1 + k_2 m_2, \quad m_i = \frac{l_i}{l} = \frac{V_i}{V} \quad (i = 1, 2). \quad (6)$$

It is known that the thermal  $R_t$  and electrical  $R_e$  resistances for a parallelepiped of length  $L$ , width  $\ell$ , and height  $h$  are determined from the formulas

$$R_t = \frac{L}{h\ell\lambda}, \quad R_e = \frac{L}{h\ell\sigma}. \quad (7)$$

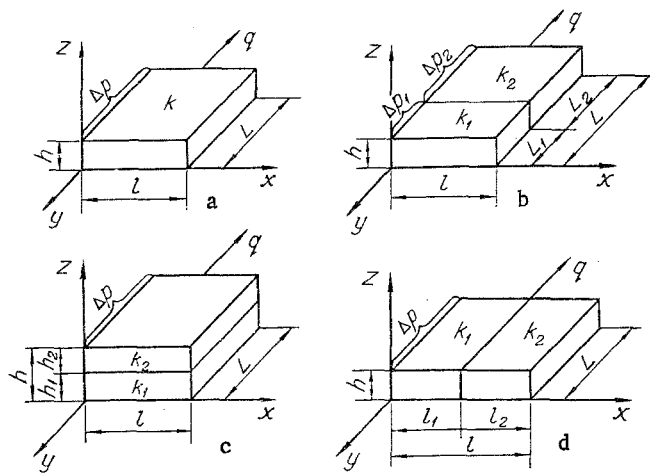

Fig. 1. Layer arrangements for calculating the permeability of elementary systems.

By analogy with the above, we introduce the concept of the filtration resistance of the system

$$R_f = \frac{L}{h l k / \mu} \quad (8)$$

Given this, Eq. (4) represents the case of serial  $R_f = R_{f1} + R_{f2}$ , and Eqs. (5) and (6) represent parallel connection of the filtration resistances  $R_f^{-1} = R_{f1}^{-1} + R_{f2}^{-1}$ . Thus, Kirchhoff's laws for circuits can be used in calculating the filtration resistance of an inhomogeneous porous system.

Let us now examine a structure in which a change in the concentration of the components is accompanied by a transition from a structure with isolated impregnations to a structure with mutually penetrating components. The general topological pattern of structural change in a heterogeneous system accompanying a change in the concentration of the components has become clear from studies in flow theory (or percolation theory) [1, 2]. It follows from flow theory that, at small values of porosity  $m_2$ , the pores in the material are either isolated or are in the form of isolated accumulations or "clusters." Large pore accumulations appear as  $m_2$  increases and these larger accumulations, together with the small accumulations, form so-called isolated clusters (IC). When the porosity becomes equal to the critical value  $m_c$ , the IC merge and form the so-called infinite cluster (FC), and the system becomes conductive. With a further increase in  $m_2 > m_c$ , the FC enlarge and pores permeate the entire system, forming the structure with mutually penetrating components. The value of  $m_2 = m_c$  is called the flow threshold. When  $m_2 = m_c$ , the permeability of porous materials "jumps" from zero to a certain value, then changing monotonically with an increase in porosity. This jump in permeability was observed experimentally by Tertsagi [3] in studying the permeability of porous materials. He empirically determined that permeability is nearly zero at a porosity  $m_2 < 13\%$ .

The author of [4] described a model constructed using the method of combining flow theory with reduction to a unit cell. We will use this model (Fig. 2a) to calculate the permeability of porous materials. Here, isolated clusters (pores) are modeled by individual cubical inclusions (side  $l_2$ ). The IC's are connected to each other by conductive links with a cross section  $l_1$ . The topology of the model changes with an increase in  $m_2$ : at low porosities  $m_2 < m_c$ , the system contains closed inclusions (IC's) (Fig. 2c). The first links between the IC's then begin to appear. A further increase in porosity  $m_2$  leads to an increase in the area of the cross section  $l_1^2$  of the links until the values of  $l_1$  and  $l_2$  are equal ( $m_2 = 0.5$ ) and the heterogeneous system is transformed into a structure with mutually penetrating components (Fig. 2d). The following relation can be used to express the law of change in the effective cross section  $S_1$  of the conductive FC, allowing here for both the complex topology of the FC and the probability nature of its formation

$$S_1 = \left( \frac{l_1}{L} \right)^2 = 0.25 \left( \frac{m_2 - m_c}{0.5 - m_c} \right)^2, \quad (9)$$

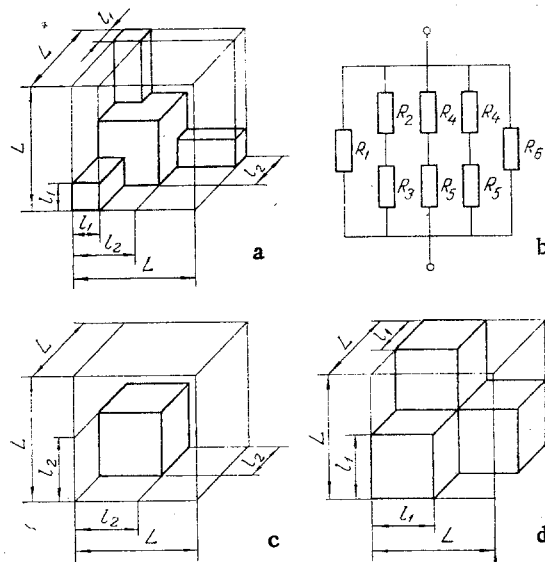

Fig. 2. Generalized model of a heterogeneous system: a) general view (at  $m_2 > m_c$ ); b) equivalent circuit of filtration resistances; c) model of isolated cluster ( $m_2 \leq m_c$ ); d) model with mutually penetrating components.

where  $m_c = 0.15 \pm 0.03$ ;  $t = 1.8 \pm 0.2$  [2, 5]. For subsequent calculations, we will take  $m_c = 0.15$  and  $t = 1.6$ .

Let us analyze the fluid transport process in the unit cell (Fig. 2a). We will introduce the notions of "pore permeability"  $k_2$  and "shell permeability"  $k_1$ , with  $k_1 = 0$ . We will divide the shell into separate sections consisting of surfaces which are impermeable for the streamlines and are parallel to the general direction of filtration of fluid flow and the lateral faces of the cell. Having written down the values of the filtration resistances of these sections, a circuit diagram of which is shown in Fig. 2b, we obtain a formula for calculating the permeability of porous materials on the basis of the above model under the condition that the "shell permeability"  $k_1 = 0$ :

$$k = k_2 c^2, \quad c = \frac{l_1}{L}, \quad (10)$$

$$\text{at } m_c < m_2 \leq 0.5 \quad c = 0.5 \left( \frac{m_2 - m_c}{0.5 - m_c} \right)^{0.8}, \quad (11)$$

$$\text{at } 0.5 < m_2 \leq 1.0 \quad 2c^3 - 3c^2 + m_2 = 0.$$

We now find the "pore permeability"  $k_2$  on the basis of the following considerations. The rate of flow of a fluid through capillary tubes is given by the Hagen-Poiseuille law

$$q = S_1 \delta^2 \Delta p / (32 \mu L_1), \quad (12)$$

where  $\delta$ ,  $S_1 = l_1^2$  are the diameter and cross-sectional area of the capillary tube (FC);  $L_1$  is the length of the capillary tube (FC) or the length of the path of a fluid particle in a sample (unit cell). On the other hand, the rate of flow of the fluid through the unit cell can be found from Darcy's law (1). In this case,  $L$  and  $S = L^2$  are the thickness and cross sectional area of the unit cell. Equating Eqs. (1) and (2), we obtain an expression for  $k$  of the unit cell:

$$k = \frac{\delta^2}{32} \frac{L}{L_1} \frac{S_1}{S} = \frac{\delta^2}{32} \frac{l_1^2}{L^2} \frac{L}{L_1} = \frac{\delta^2}{32 \tau} c^2, \quad (13)$$

where  $\tau = L_1/L$  is the sinuousness of the pore (FC). It is apparent from a comparison of Eqs. (10) and (13) that the "pore permeability"

$$k_2 = \delta^2 / (32 \tau). \quad (14)$$

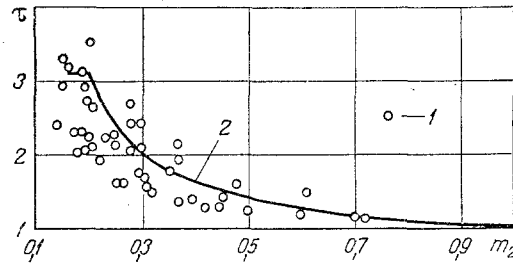

Fig. 3. Connection between sinuousness coefficient and porosity: 1) experimental data [7-10]; 2) data calculated from Eq. (16).

Conducting experiments with a computer in [6], investigators developed qualitative and quantitative representations of characteristic lengths of an infinite cluster and obtained an expression for the sinuousness of an FC

$$\tau = \frac{L_1}{L} = (m_2 - m_c)^{-0.4}. \quad (15)$$

The sinuousness of the FC decreases with an increase in  $m_2$  and must equal unity at  $m_2 = 1$ . To satisfy this condition, we convert Eq. (15) to the form

$$\tau = \frac{L_1}{L} = \left( \frac{1 - m_c}{m_2 - m_c} \right)^{0.4}. \quad (16)$$

It is noted in [6] that even at very low  $m_2 - m_c$  within the range  $0.001 < m_2 - m_c < 0.01$ , the mean length of an FC is altogether three times greater than the length of the sample. In accordance with this and experimental data on pore sinuousness [7-10], we will assume that  $\tau = \text{const}$  at  $m_c < m_2 \leq 0.2$  and that it obeys Eq. (16) at  $m_2 > 0.2$  (Fig. 3).

Equation (13) includes the capillary-tube diameter  $\delta$ , which is not known in most cases. We may take the mean distance between fibers as the mean capillary-tube (pore) diameter for fibrous materials. The distance between fibers depends on the size of the fibers in cross section and the porosity of the material. We will express the mean pore diameter through the diameter of the fibers  $d$ . It will be assumed that

$$l_1 = \delta, \quad L - l_1 = d. \quad (17)$$

The parameters of the unit cell  $l_1$ ,  $c$ , and  $L$  are connected by the relation  $l_1/L = c$ , so that  $L = l_1/c = \delta/c$ . On the basis of the last expression and Eqs. (17), we find the mean distance between the beams in the shell (the pore diameter):

$$\delta = d \left( \frac{1}{c} - 1 \right)^{-1}.$$

From the equality of the areas of the cross sections of cylindrical and square fibers, we obtain the final expression for the mean pore diameter:

$$\delta = 0.886 d \left( \frac{1}{c} - 1 \right)^{-1}, \quad (18)$$

where  $c$  is determined from (11).

We will check the applicability of the above model and the formula obtained with it to the calculation of the gas permeability of sintered fibrous materials used for lamp electrodes [11-13]. Results of calculation of permeability by Eq. (10) are compared with experimental results in Fig. 4. The theoretical results agree well both qualitatively and quantitatively with the empirical data. The divergence of the former from the latter for 38 points is 32%, with a confidence level  $p = 0.67$ .

It is thus apparent that permeability must be determined by the geometry of the pore structure of a material. Many attempts have been made to develop a theory connecting pore structure geometry with permeability. Sheidegger made a very thorough survey of these theories in [14]. The most widely adopted models are those in which the porous medium is represented as a bundle of parallel capillary tubes of equal length. In reality, the pore

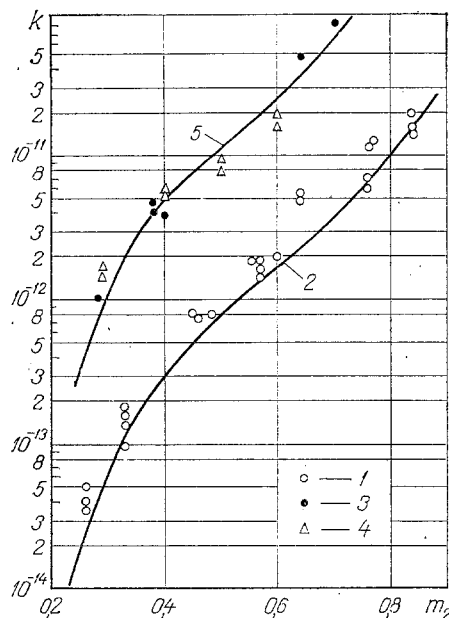

Fig. 4. Comparison of experimental and theoretical results: 1) experiment [12]; 2) estimate from Eq. (10); 3, 4) experiment [11, 13]; 5) estimate from Eq. (10).  $k$ ,  $m^2$ .

structure of materials is much more complicated. Thus, this work has examined a new model based on flow theory with allowance for the complex geometry of pores and the probability nature of their formation.

#### NOTATION

$q$ , volumetric flow rate of fluid;  $l$ ,  $h$ ,  $L$ ,  $S$ , width, thickness, length, and cross-sectional area of material;  $\Delta p$ , pressure drop;  $\mu$ , coefficient of absolute viscosity;  $k$ ,  $k_1$ ,  $k_2$ , permeabilities;  $m_1$ ,  $m_2$ , volume concentrations of components;  $R_t$ ,  $R_e$ ,  $R_f$ , thermal, electrical, and filtration resistances;  $\lambda$ ,  $\sigma$ , thermal and electrical conductivities;  $c$ , parameter;  $\delta$ , mean pore diameter;  $\tau$ , sinuousness;  $d$ , fiber diameter.

#### LITERATURE CITED

1. S. Kirkpatrick, "Percolation and conductivity," *Rev. Mod. Phys.*, **45**, No. 4, 574-608 (1973).
2. B. I. Shklovskii and A. L. Éfros, "Theory of flow and the conductivity of highly non-uniform media," *Usp. Fiz. Nauk*, **117**, No. 3, 401-407 (1975).
3. L. S. Leibenzon, *Movement of Natural Liquids and Gases in a Porous Medium* [in Russian], GITTL, Moscow-Leningrad (1947).
4. G. N. Dul'nev and V. V. Novikov, "Conductivity of heterogeneous systems," *Inzh.-Fiz. Zh.*, **36**, No. 5, 901-910 (1979).
5. V. K. S. Shante and S. Kirkpatrick, "An introduction to percolation theory," *Adv. Phys.*, **20**, No. 85, 325-332 (1971).
6. A. S. Skal and B. I. Shklovskii, "Topology of an infinite cluster in flow theory and the theory of sudden conductivity," *Fiz. Tekh. Poluprovodn.*, **8**, No. 8, 1586-1592 (1974).
7. V. K. Sorokin, "Pore size in cermets," *Poroshk. Metall.*, No. 1, 60-62 (1973).
8. O. Krisher, *Scientific Principles of Drying Technology* [Russian translation], IL, Moscow (1961).
9. M. R. J. Willie and M. B. Spangler, "Application of electrical resistivity measurements to the problem of fluid flow in porous media," *Bull. Am. Assoc. Pet. Geol.*, **36**, No. 2, 359-403 (1952).
10. W. O. Winsauer, H. M. Shearing, and P. H. Masson, "Resistivity of brine-saturated sands in relation to pore geometry," *Bull. Am. Assoc. Pet. Geol.*, **36**, No. 2, 253-277 (1952).
11. A. G. Kostornov and M. S. Shevchuk, "Study of the hydraulic characteristics and structure of porous materials made of metallic fibers," *Poroshk. Metall.*, No. 9, 24-31 (1973).
12. A. L. Moroz et al., "Certain properties of permeable materials made of fine iron fibers," *Poroshk. Metall.*, No. 4, 47-50 (1978).

13. A. G. Kostornov et al., "Porous permeable materials made of nickel fibers," Poroshk. Metall., No. 1, 13-19 (1976).
14. A. E. Sheidegger, Physics of the Flow of Liquids in a Porous Medium [in Russian], GTTI, Moscow-Leningrad (1960).

## HEAT EXCHANGE IN POROUS MEDIA

B. M. Galitseiskii and A. N. Ushakov

UDC 536.24

Results are offered from an experimental study of the heat-exchange process in porous materials and the effect on this process of high-frequency oscillations in the heat-exchange fluid flow.

The study of heat exchange and its intensification in porous materials is a problem of practical interest, inasmuch as such materials are finding ever wider use as construction materials for surfaces drafted by high-temperature flows. Both stationary and nonstationary heat-exchange processes in porous materials are of great interest.

The goal of the present study is to examine the heat-exchange process in porous materials and the effect upon this process of high-frequency oscillations in the heat-exchange fluid flow.

The one-dimensional method of describing the heat-exchange process in porous structures will be used. For a plate of porosity  $\Pi$  with internal heat source  $q_v$  the problem reduces to solution of the thermal balance equations

$$\frac{d^2 T_w}{dx^2} - \frac{GC_p}{F_\Sigma \lambda_M} \frac{dT_f}{dx} + \frac{q_v(1-\Pi)}{\lambda_M} = 0, \quad (1)$$

$$\frac{GC_p}{F_\Sigma} \frac{dT_f}{dx} = \alpha_v(T_w - T_f), \quad (2)$$

where  $\Pi$  is the porosity, defined as the ratio of the pore volume to the total plate volume, and  $\alpha_v$  is the heat-liberation coefficient, characterizing the heat produced per unit volume of the porous material.

Up to the present most authors have studied the mean heat liberation coefficient without consideration of the effect of heat exchange on the specimen boundaries. Results as to the effect of boundary conditions on the heat-liberation coefficient in porous structures  $\alpha_v$  are extremely contradictory. According to [1-3], heat exchange at the boundaries of a porous specimen does not affect heat exchange within the pores, while according to [4] and [5], this effect can be significant. In connection with this fact, in the present study the effect of heat exchange at the specimen boundaries on heat exchange within the porous structure was considered in addition to a study without consideration of heat exchange at the boundaries. For this purpose two variants of boundary conditions were considered for Eqs. (1), (2).

In the first variant heat exchange at the specimen boundaries was ignored, and the boundary conditions had the following form:

$$\left. \begin{aligned} x=0, \lambda_M \frac{dT_w}{dx} &= 0, \\ x=\delta, \lambda_M \frac{dT_w}{dx} &= 0. \end{aligned} \right\} \quad (3)$$

In the second variant heat exchange at the input (the boundary where coolant enters) boundary was considered, and the boundary conditions had the form

$$x=0, \lambda_M \frac{dT_w}{dx} = \alpha_{in}(T_{w_1} - T_{f_0}), \quad (4)$$